

# NEXUS MACHINERY



## CANGZHOU NEXUS MACHINERY CO.,LTD

手机: 0086 15297391305  
邮箱: ceo@nexusmachinery.com  
微信: nexusmachinery  
网址: www.rollformingmachinesupplier.com  
地址: 中国河北省沧州市工业开发区

MOB: 0086 139 3074 9354  
EMAIL: roger@nexusmachinery.com  
SKYPE: roger891219@hotmail.com  
WEB: www.rollformingmachinesupplier.com  
ADD: INDURSTAIL PARK, CANGZHOU CITY, HEBEI PROVINCE, CHINA



WECHAT



WEBSITE



NEXUS MACHINERY

## ROLL FORMING MACHINE SUPPLIER 冷弯成型设备供应商



CANGZHOU NEXUS MACHINERY CO.,LTD  
沧州奈克瑟斯机械有限公司



## Company Introduction

Established in 2005, Cangzhou Nexus Machinery Co.,Ltd is an experienced manufacturer & exporter of cold roll forming machine with ISO quality system.

Company main products include: Color Steel Roof Sheet Roll Forming Machine, Floor Deck Roll Forming Machine, Light Steel Keel Roll Forming Machine, C/Z Purlin Roll Forming Machine, Highway Guardrail Roll Forming Machine, Door Frame Roll Forming Machine, Slitting Line, Cutting Line, Hydraulic Bending Machine, Hydraulic Curving Machine, Hydraulic Decoiler, Automatic Stacker etc. We also can supply steel coils, roof panels to suit diverse requirements of our global customers.

Today, Cangzhou Nexus Machinery Co.,Ltd has exported its machines more than 50 Countries and Regions. Such as America, Chile, Mexico, Bolivia, Brazil, Colombia, Argentina, Ecuador, Honduras, Fiji, Papua New Guinea, Kuwait, Syria, Oman, Saudi Arabia, U.A.E, Nigeria, Tanzania, Ethiopia, Gana, Guinea, South Africa, Algeria, India, Australia, Philippines, Indonesia, Azerbaijan and Kazakhstan.

Advantages of Cangzhou Nexus Machinery Co.,Ltd are rich experience for cold roll forming machine solution, competitive price and excellent service. We will continue to do our best to supply perfect products and service for customers. Invite you to contact us for further information.

### Workshop Scene



## Product Contents

梯形屋面瓦成型机..... 01 TRAPEZOIDAL ROOF SHEET ROLL FORMING MACHINE	C型檩条成型机..... 13 C PURLIN ROLL FORMING MACHINE
波纹屋面瓦成型机..... 02 CORRUGATED ROOF SHEET ROLL FORMING MACHINE	C/Z自动换型檩条成型机..... 14 C/Z INTERCHANGE PURLIN ROLL FORMING MACHINE
琉璃瓦成型机..... 03 GLAZED TILE ROLL FORMING MACHINE	卷帘门成型机.....15 ROLLING SHUTTER DOOR FORMING MACHINE
高强度波纹横压机..... 04 G550 IRON SHEET BARREL CORRUGATION MACHINE	门框成型机..... 16 DOOR FRAME ROLL FORMING MACHINE
双层屋面瓦成型机..... 05 DOUBLE LAYER ROOFING ROLL FORMING MACHINE	太阳能光伏支架生产线..... 17 SOLAR PHOTOVOLTAIC RACK PRODUCTION LINE
导柱式彩钢瓦成型机..... 06 GUIDE PIN ROOFING ROLL FORMING MACHINE	超市货架立柱生产线..... 18 SUPERMARKET GOODS UPRIGHT RACK PRODUCTION LINE
楼承板成型设备..... 07 FLOOR DECK ROLL FORMING MACHINE	0.2-2.0毫米薄板纵剪线..... 19 0.2MM-2.0MM THICK SIMPLE SLITTING LINE
高速护栏成型设备..... 08 HIGHWAY GUARDRAIL ROLL FORMING MACHINE	3.0毫米厚板纵剪线..... 20 3.0MM THICK HEAVY DUTY SLITTING LINE
50/75/100龙骨成型机..... 09 50/75/100 CU STUD&TRACK ROLL FORMING MACHINE	异型钢成型机..... 21 ALLOYTYPE STEEL ROLL FORMING MACHINE
60/27/28 龙骨成型机..... 10 60/27/28 CU STUD&TRACK ROLL FORMING MACHINE	液压放料架 & 折弯机..... 22 DECOILER & BENDING MACHINE
小帽龙骨成型机..... 11 OMEGA ROLL FORMING MACHINE	自动码垛 & 剪板机..... 23 STACKER & SHEARING MACHINE
角钢成型机..... 12 WALL ANGLE ROLL FORMING MACHINE	版型图集..... 24 DRAWING PROFILE

梯形屋面瓦成型机  
TRAPEZOIDAL ROOF SHEET ROLL FORMING MACHINE



Drawing Profile:

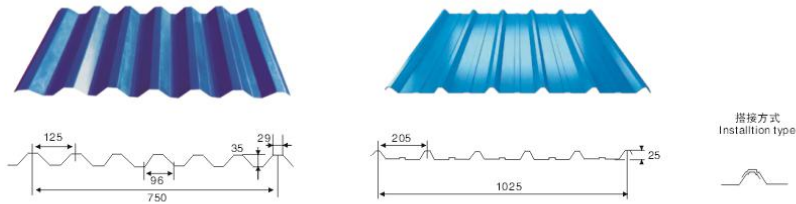

Flow Chart:

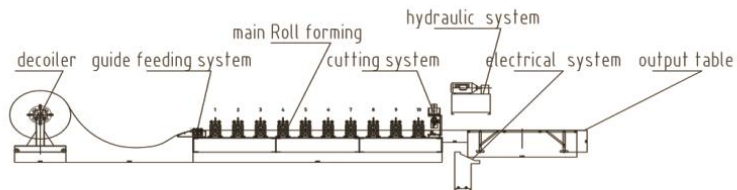

波纹屋面瓦成型机  
CORRUGATED ROOF SHEET ROLL FORMING MACHINE



Drawing Profile:

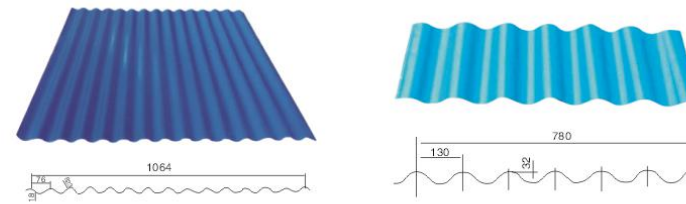

Flow Chart:

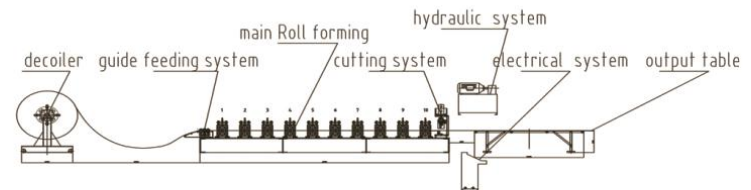

琉璃瓦成型机  
GLAZED TILE ROLL FORMING MACHINE

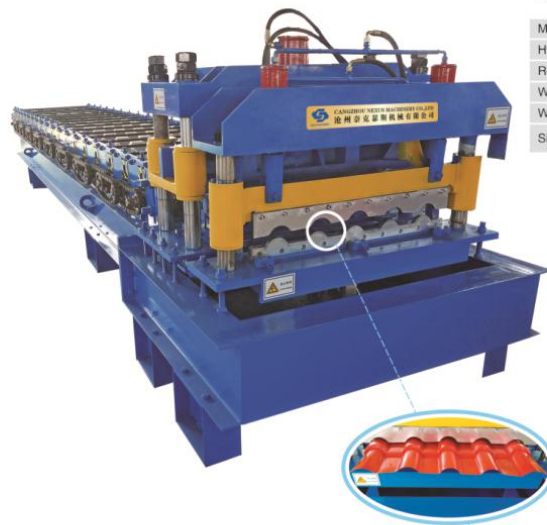

Main Parameters:

Main motor power	5.5 KW
Hydraulic power	4 KW
Roll station	About 14 steps
Working speed	3m—5m/min
Weight of machine	about 4 ton
Size of machine	About 7.5 x 1.5 x 1.4m (L x W x H)

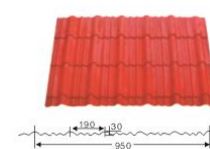
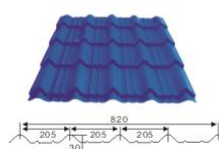
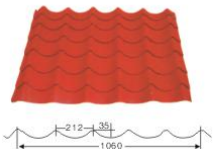
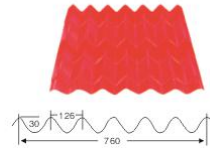
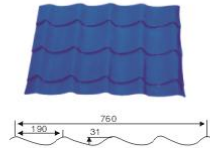
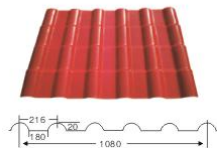
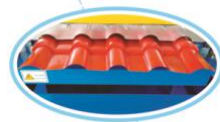

高强度波纹横压机  
G550 IRON SHEET BARREL CORRUGATION MACHINE

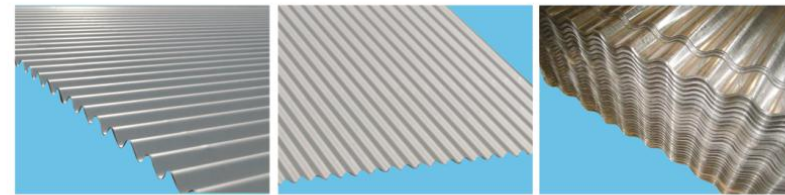
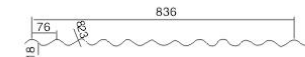

The production line mainly includes:

Feeding platform, driven motor, reduction gears, driven system, roll forming rollers, and computer control cabinet, etc. This line adopts alternating current motor to drive, and formed by welded by welded steel sheet welded, which makes more reliable and stronger.  
Suitable material: G550 galvanized sheet, aluminum sheet  
Thickness range: 0.15—0.25mm  
Forming length: 2.2m, 3.6m, 3.7m, 4.0m  
Forming width: 1.0m  
Voltage: 380V/415V, 50Hz, 3 phases



● 双层屋面瓦成型机  
DOUBLE LAYER ROOFING ROLL FORMING MACHINE

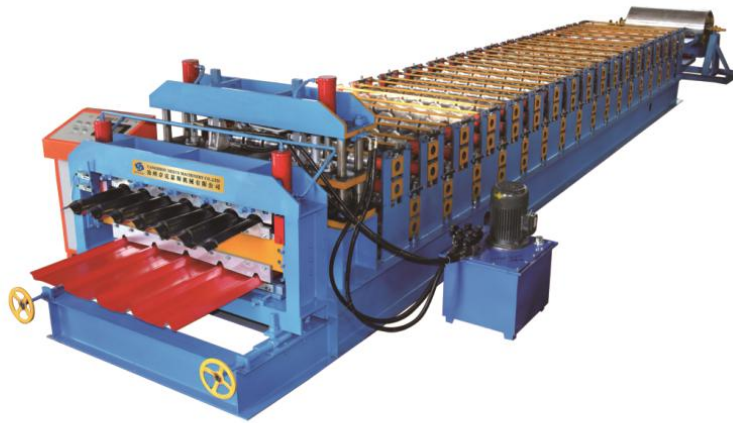

● 导柱式彩钢瓦成型机  
GUIDE PIN ROOFING ROLL FORMING MACHINE

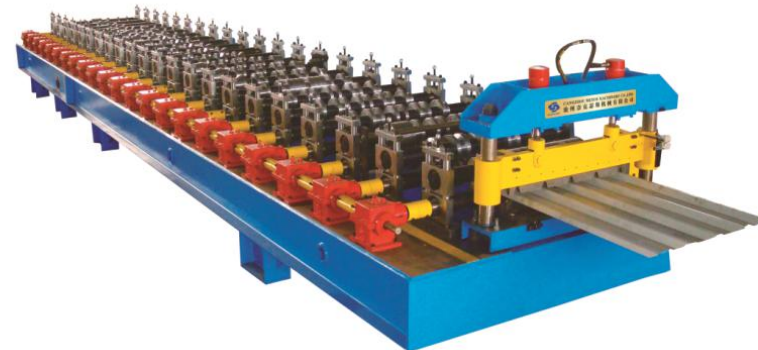
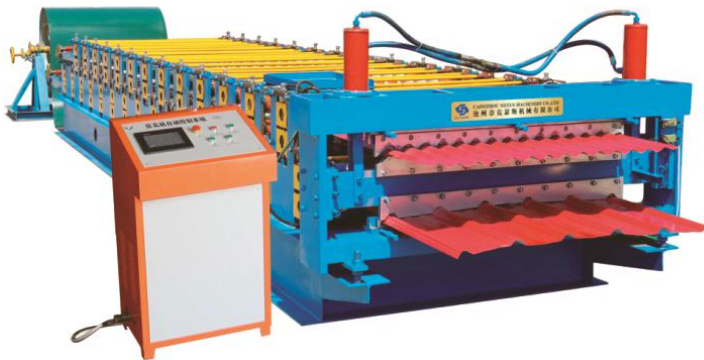
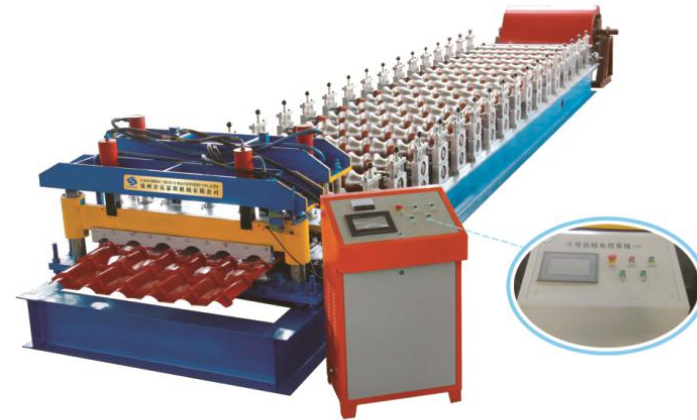



楼承板成型设备  
FLOOR DECK ROLL FORMING MACHINE

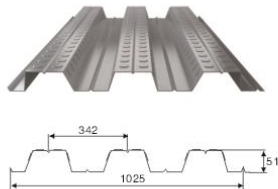

展开宽度(Cover width): 1250mm

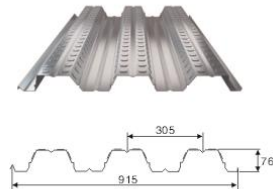

展开宽度(Cover width): 1250mm

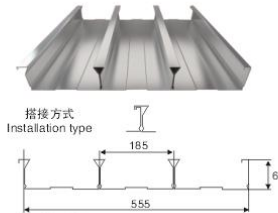

搭接方式  
Installation type

展开宽度(Cover width): 1200mm

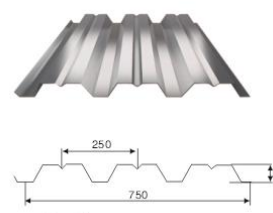

展开宽度(Cover width): 1000mm

高速护栏成型设备  
HIGHWAY GUARDRAIL ROLL FORMING MACHINE

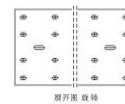
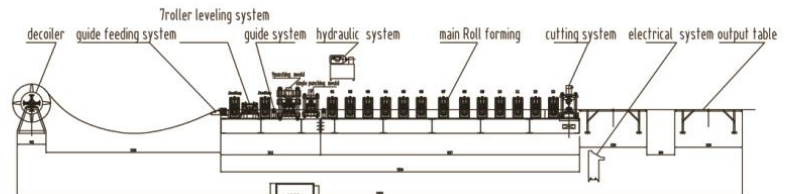
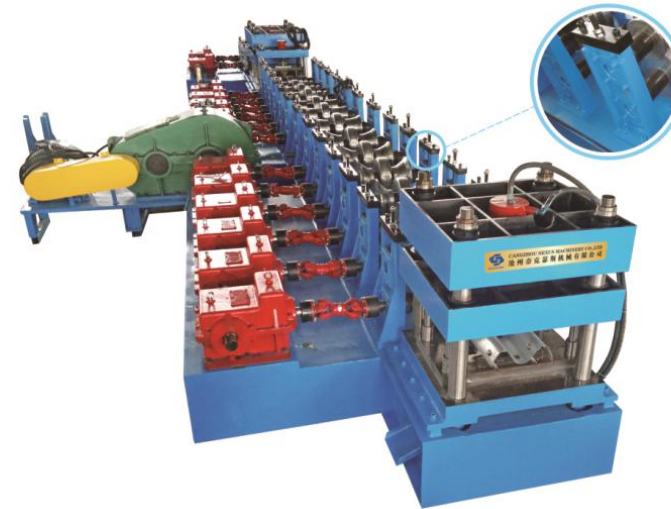

展开图 镀锌

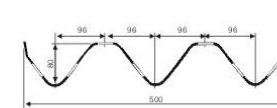
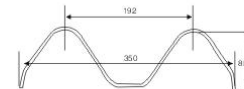

压型钢板型号 Model	有效压高深mm Effective Width	展开宽度mm Coil width	板厚mm Thickness	用途 Usage
XY85-192	305	488	3	公路护栏板 Guard Rail

压型钢板型号 Model	有效压高深mm Effective Width	展开宽度mm Coil width	板厚mm Thickness	用途 Usage
XY90-500	500	750	3	公路护栏板 Guard Rail

50/75/100龙骨成型机  
50/75/100 CU STUD&TRACK ROLL FORMING MACHINE

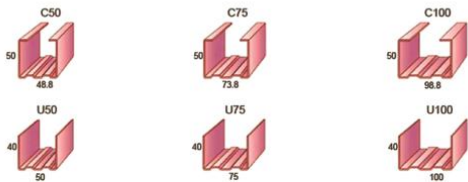
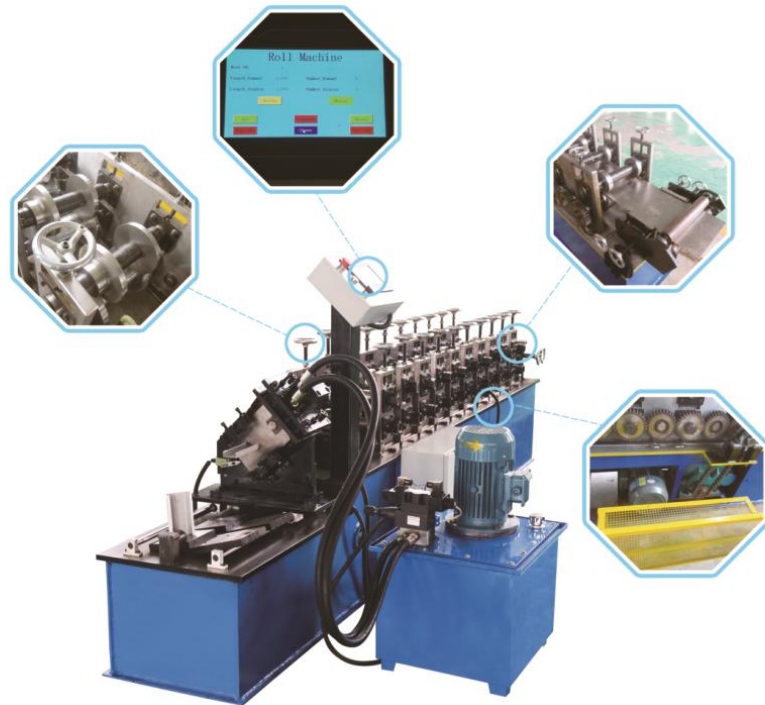

60/27/28 龙骨成型机  
60/27/28 CU STUD&TRACK ROLL FORMING MACHINE

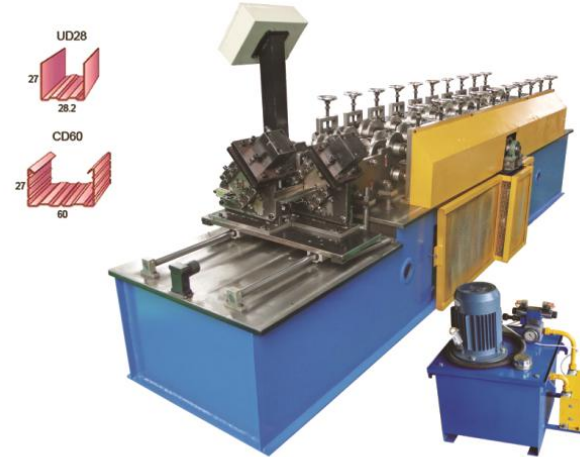

Machine Details:

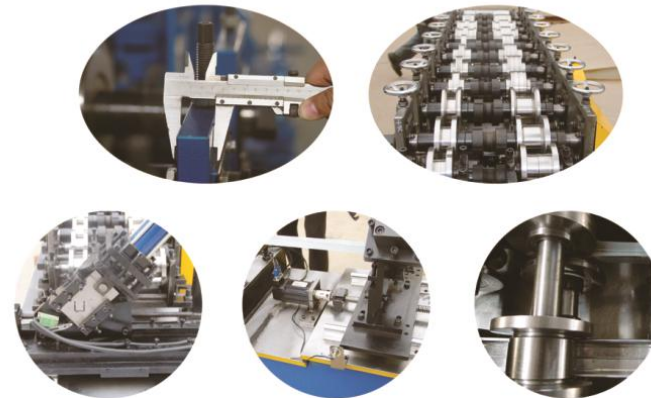

**小帽龙骨成型机**  
OMEGA ROLL FORMING MACHINE

Drawing Profile:

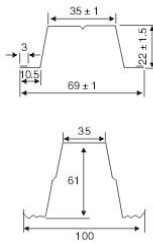

Main Parameters:

Main motor power	3 KW
Hydraulic power	3 KW
Roll station	14 steps
Working speed	10m--25m/min
Weight of machine	about 2.5 ton
Size of machine	About 6.0 x 1.2 x 1.2m (L x W x H)



Flow Chart:

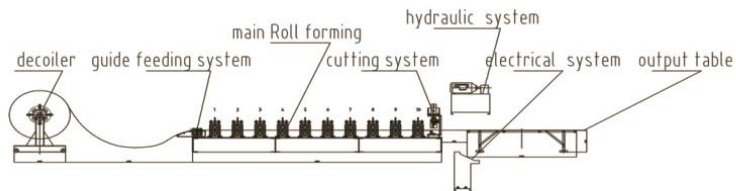

**角钢成型机**  
WALL ANGLE ROLL FORMING MACHINE



Main Parameters:

Main motor power	3 KW
Hydraulic power	3 KW
Roll station	10 steps
Working speed	15m--60m/min
Weight of machine	about 2.5 ton
Size of machine	About 5.0 x 1.2 x 1.2m (L x W x H)

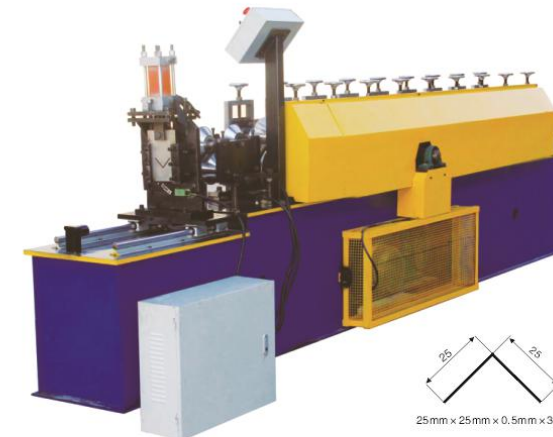



C型檩条成型机  
C PURLIN ROLL FORMING MACHINE



C/Z自动换型檩条成型机  
C/Z INTERCHANGE PURLIN ROLL FORMING MACHINE



C型钢檩条规格尺寸表 C Purlin Dimensions Table

主要用途：檩条 Usage: shape purlin	型号 Model	断面尺寸 Section size			
		h(mm)	b(mm)	c(mm)	l(mm)
	C80	80	40-80	10-20	2.0-2.5
	C100	100	40-80	10-20	2.0-3.0
	C100	100	40-80	10-20	2.0-3.0
	C120	120	40-80	10-20	2.0-3.0
	C120	120	40-80	10-20	2.0-3.0
	C140	140	40-80	10-20	2.0-3.0
	C140	140	40-80	10-20	2.0-3.0
	C160	160	40-80	10-20	2.0-3.0
	C160	160	40-80	10-20	2.0-3.0
	C180	180	40-80	10-20	2.0-3.0
	C180	180	40-80	10-20	2.0-3.0
	C200	200	40-80	10-20	2.0-3.0
	C200	200	40-80	10-20	2.0-3.0
	C220	220	40-80	10-20	2.0-3.0
	C220	220	40-80	10-20	2.0-3.0
	C240	240	40-80	10-20	2.0-3.0
	C240	240	40-80	10-20	2.0-3.0
	C240	240	40-80	10-20	2.0-3.0
	C250	250	40-80	10-20	2.0-3.0
	C250	250	40-80	10-20	2.0-3.0
	C280	280	40-80	10-20	2.0-3.0
	C300	300	40-80	10-20	2.0-3.0

C型钢工艺流程图 C Purlin Machine Flow Chart

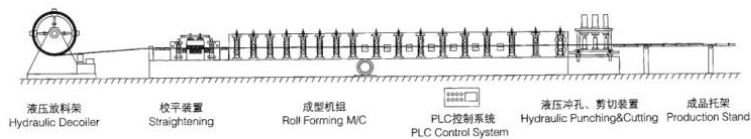

Punching 冲孔

Pre-cutting 剪切

Cable cabinet 电器柜

Z型钢檩条规格尺寸表 Z Purlin Dimensions Table

主要用途：檩条 Usage: shape purlin	型号 Model	断面尺寸 Section size			
		h(mm)	b(mm)	c(mm)	l(mm)
	Z100	100	55	20	2.0-3.0
	Z120	120	55	20	2.0-3.0
	Z140	140	55	20	2.0-3.0
	Z150	150	67	20	2.0-3.0
	Z160	160	67	20	2.0-3.0
	Z180	180	67	20	2.0-3.0
	Z200	200	67	20	2.0-3.0
	Z250	250	78	20	2.0-3.0
	Z280	280	78	20	2.0-3.0
	Z300	300	78	20	2.0-3.0

卷帘门成型机  
ROLLING SHUTTER DOOR FORMING MACHINE

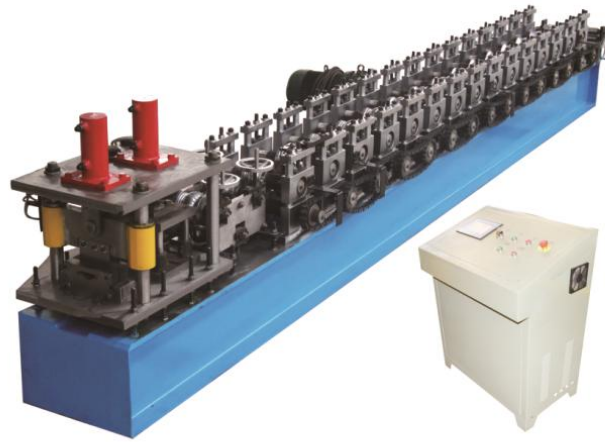

Drawing Profile:

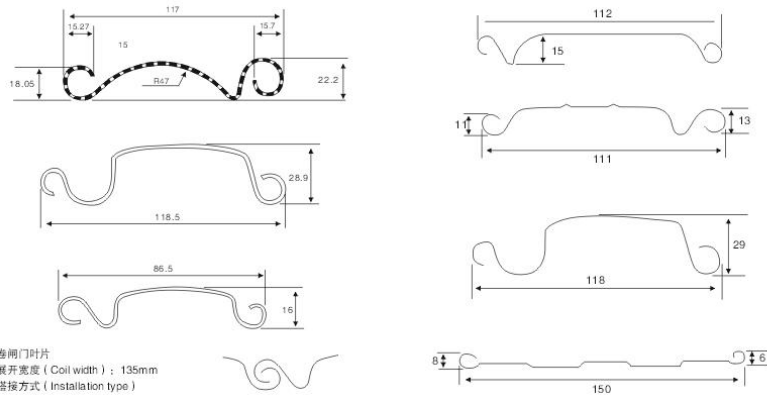

门框成型机  
DOOR FRAME ROLL FORMING MACHINE



Drawing Profile:

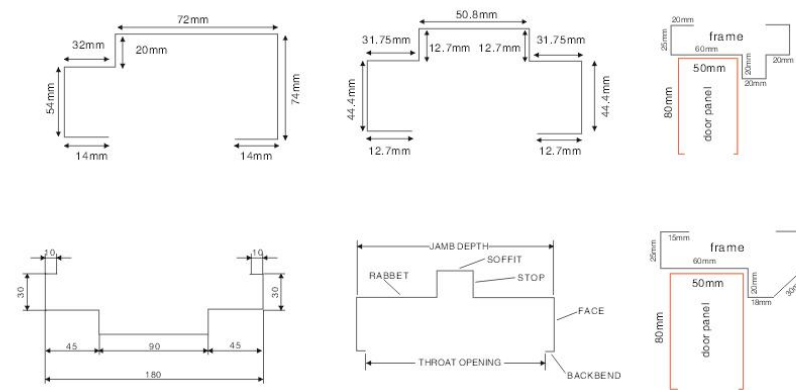

太阳能光伏支架生产线  
SOLAR PHOTOVOLTAIC RACK PRODUCTION LINE



Flow Chart:

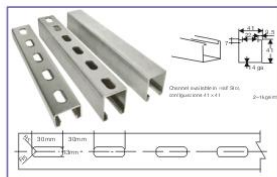
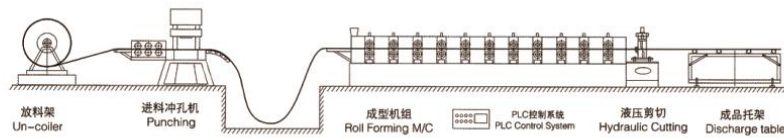

Drawings 版型图



Shearing 切断



Punching machine 冲床

超市货架立柱生产线  
SUPERMARKET GOODS UPRIGHT RACK PRODUCTION LINE

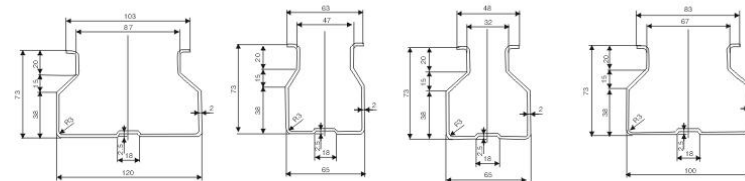
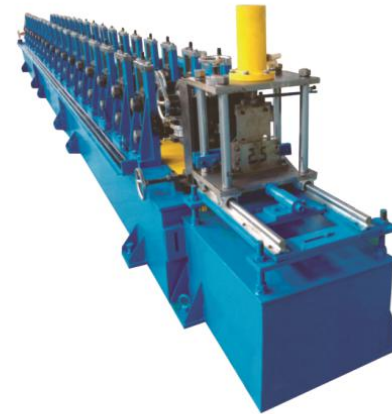

The Rack Production Line includes Decoiler, Straightening machine, Punching machine, Roll forming machine, Output table and PLC control System.

Work speed can reach 15-20 meters in one minute ,high efficiency and run stable.

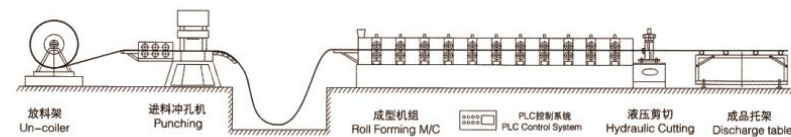

0.2-2.0毫米薄板纵剪线  
0.2MM-2.0MM THICK SIMPLE SLITTING LINE

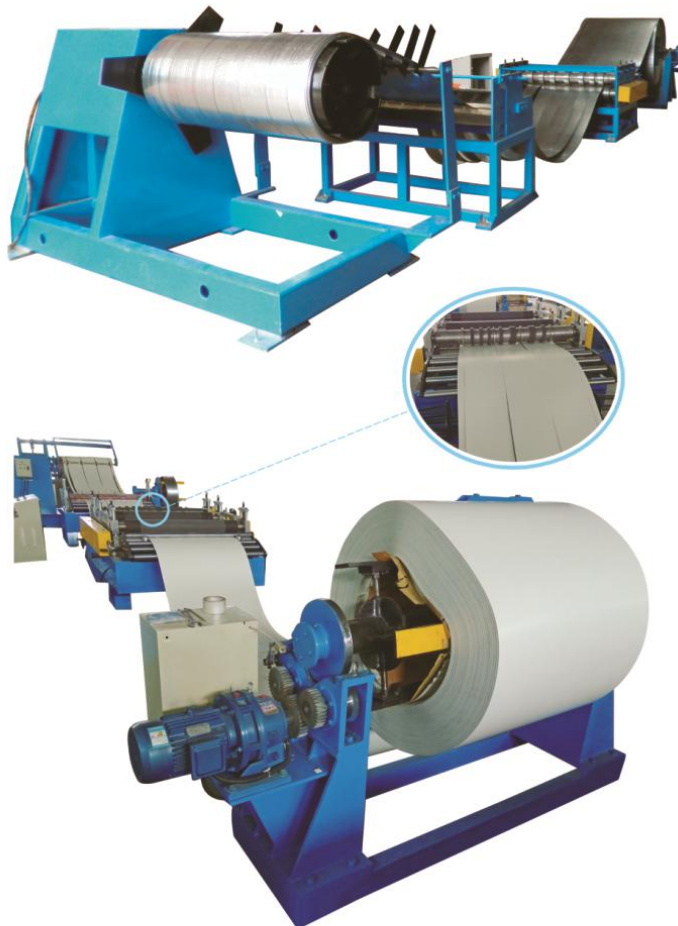

3.0毫米厚板纵剪线  
3.0MM THICK HEAVY DUTY SLITTING LINE

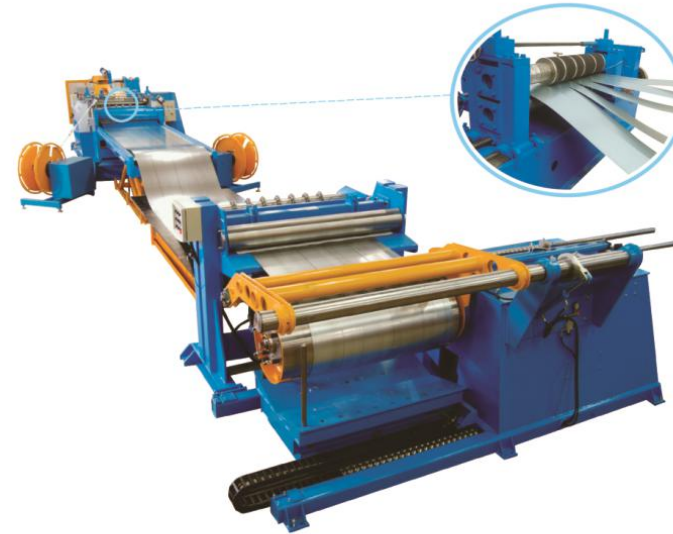

The Slitting Line consists of Decoiler, Feeding system, Leveling system, Slitting system, Scrape coil system, Correcting&Damping system, Recoiler and Electrical system. It is suitable for processing metal thickness 3.0mm, coil width range from 300-1250mm steel coils. This slitting line can run with max work speed 30m/min.

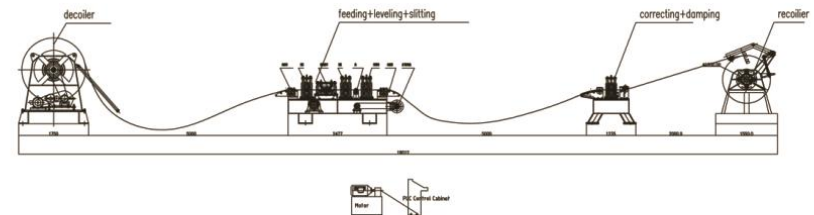

异型钢成型机  
ALLOYTYPE STEEL ROLL FORMING MACHINE

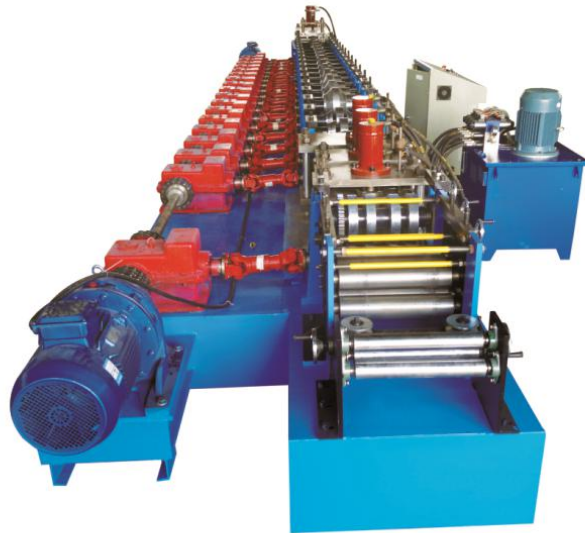

Here are some allotype steel products which produced by high precision roll forming machines. They are applied to different fields, such as, cable tray, elevator door frame, storage racking, beam, pillar, car board panel and so on.

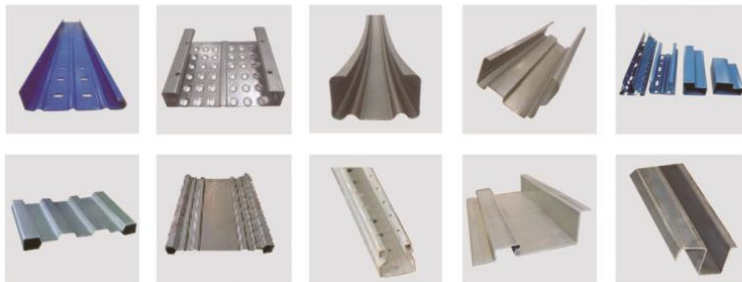

液压放料架带上料小车  
HYDRAULIC DECOILER WITH COIL CAR



液压放料架带前支撑  
HYDRAULIC DECOILER WITH FRONT SUPPORT



电动滚弯机  
MOTOR CURVING MACHINE



液压冲弯机  
HYDRAULIC CURVING MACHINE

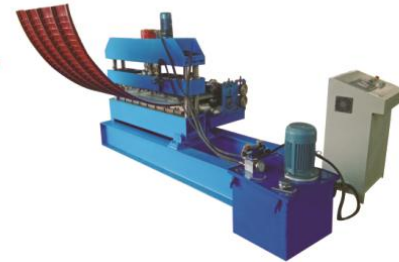

液压折弯机  
HYDRAULIC BENDING MACHINE

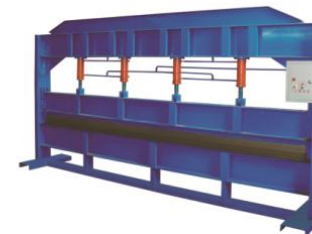

冲床  
PUNCHING MACHINE

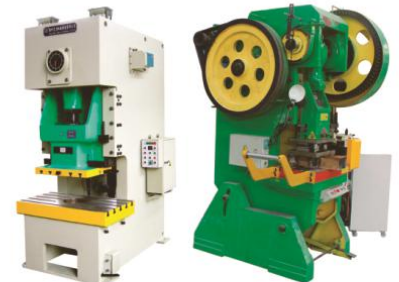



自动码垛  
AUTOMATIC STACKER



平剪机  
CUT TO LENGTH MACHINE



电动剪板机  
MOTOR SHEARING MACHINE



脚踏式剪板机  
MANUAL SHEARING MACHINE



电动分条机  
MOTOR SLITTING MACHINE

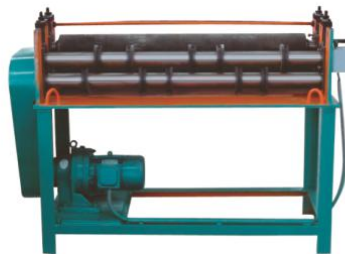

校平机  
LEVELING MACHINE

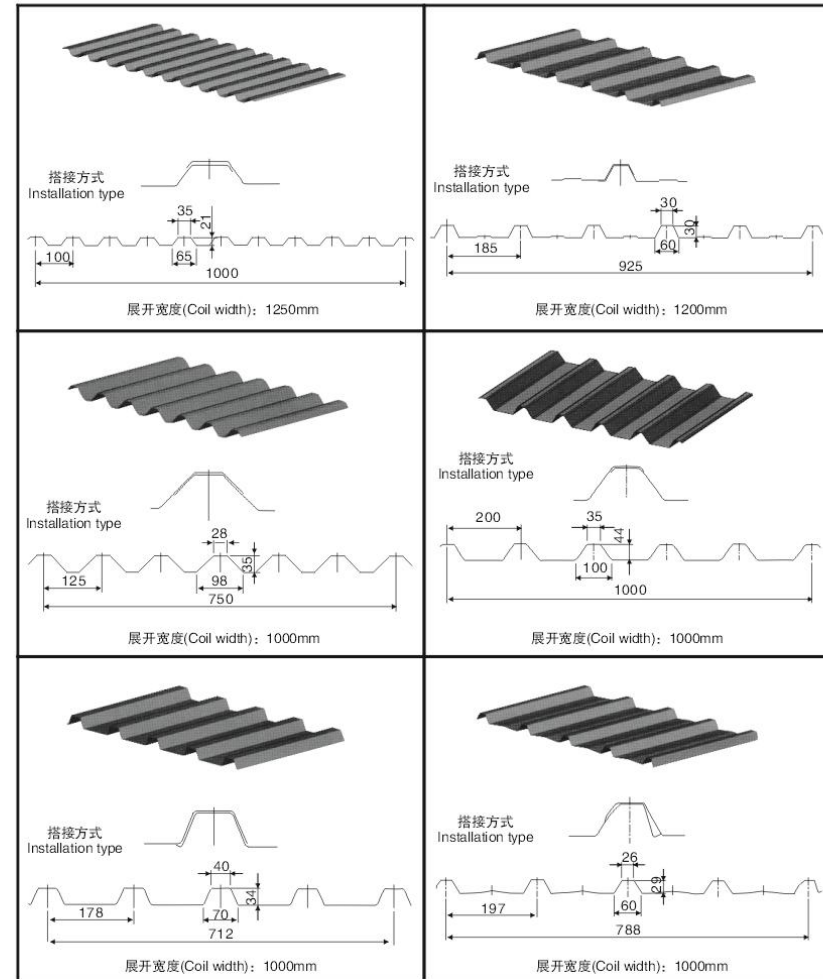

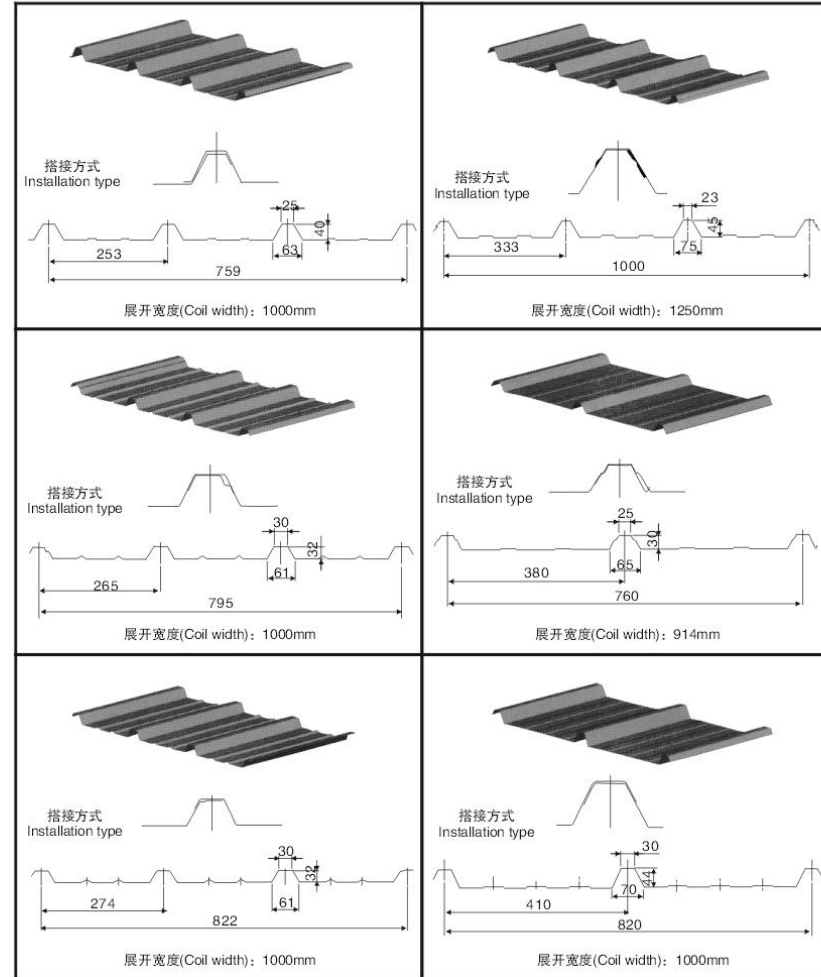
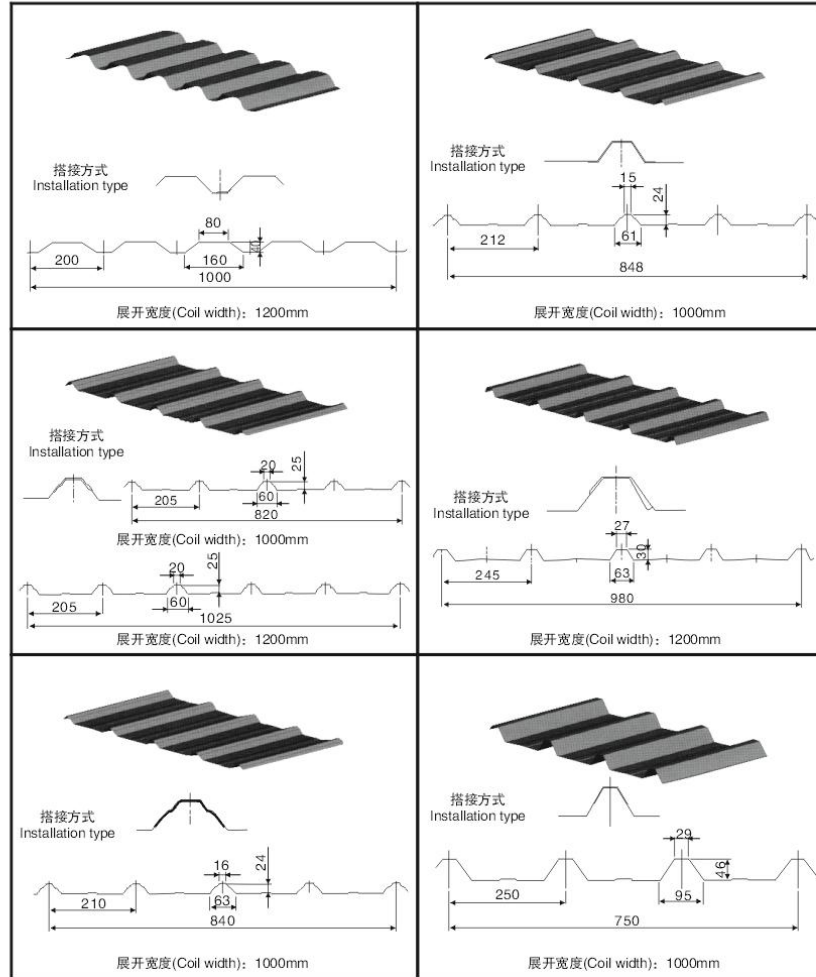

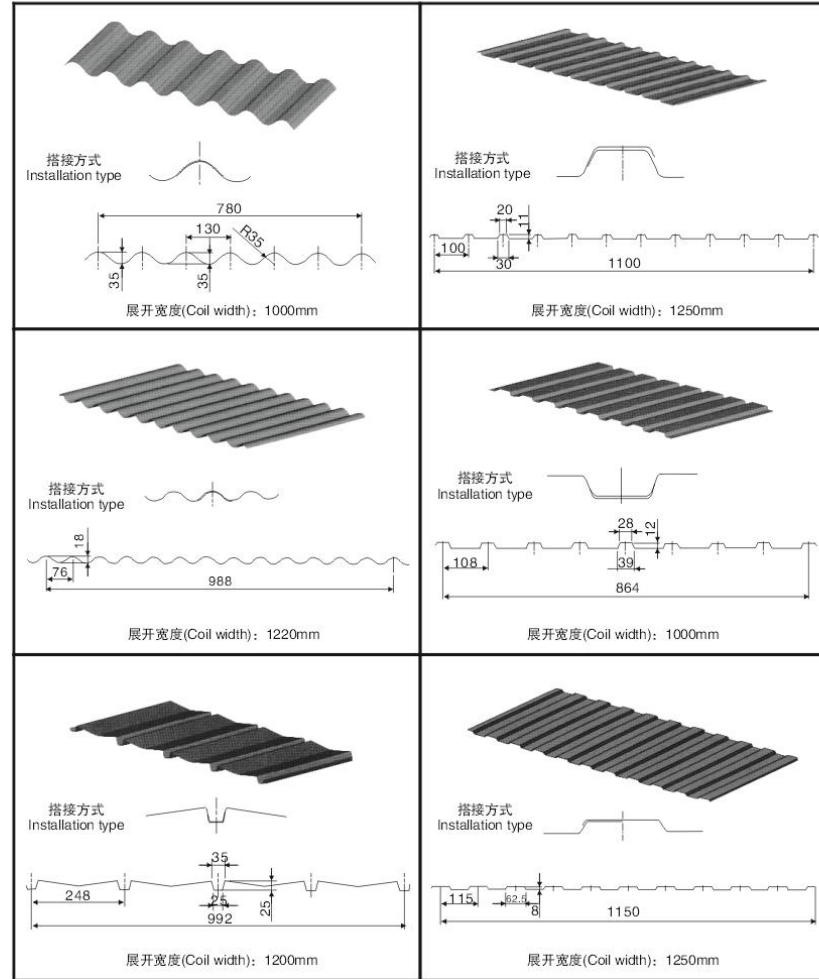
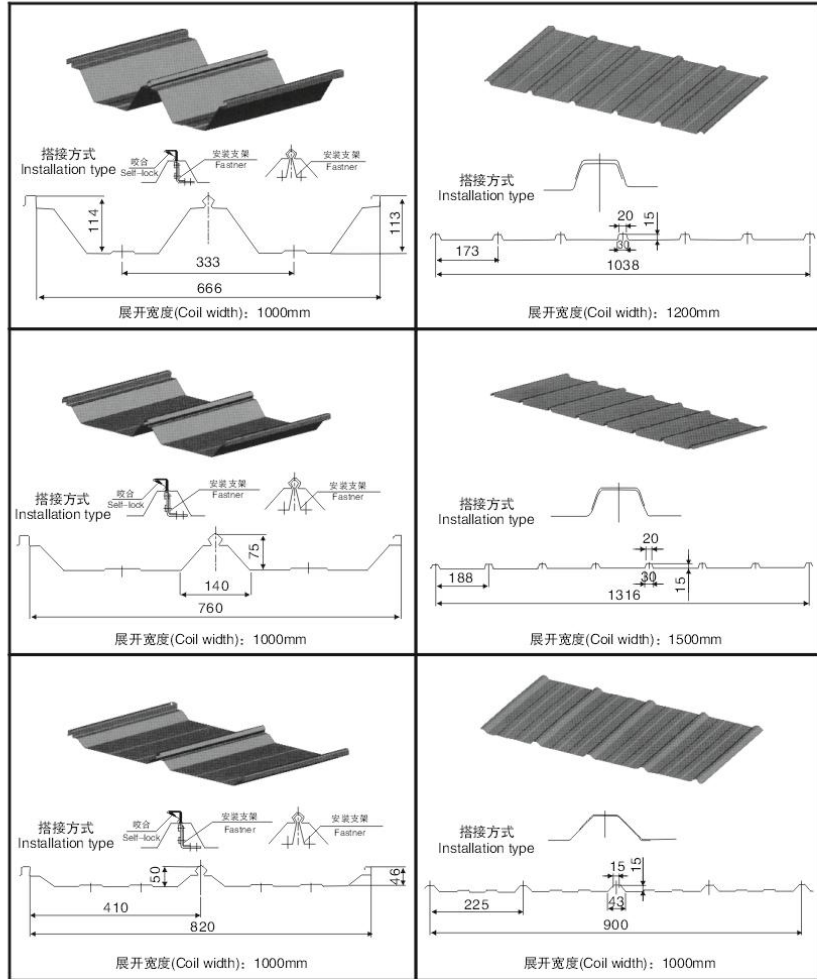



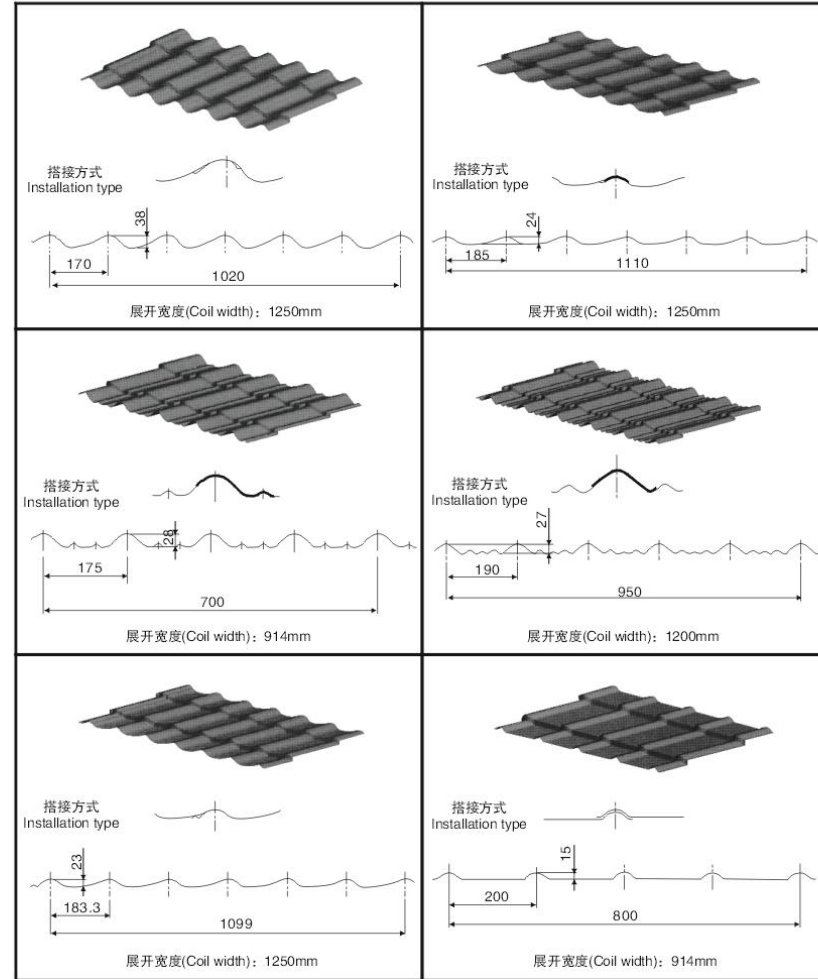
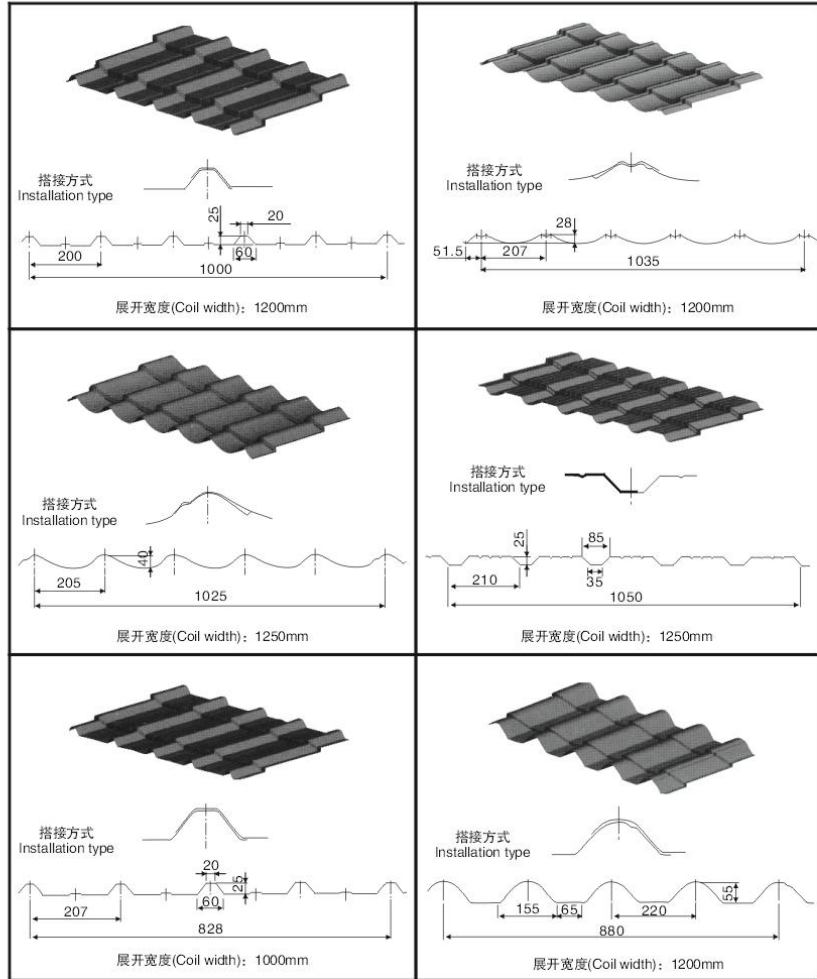

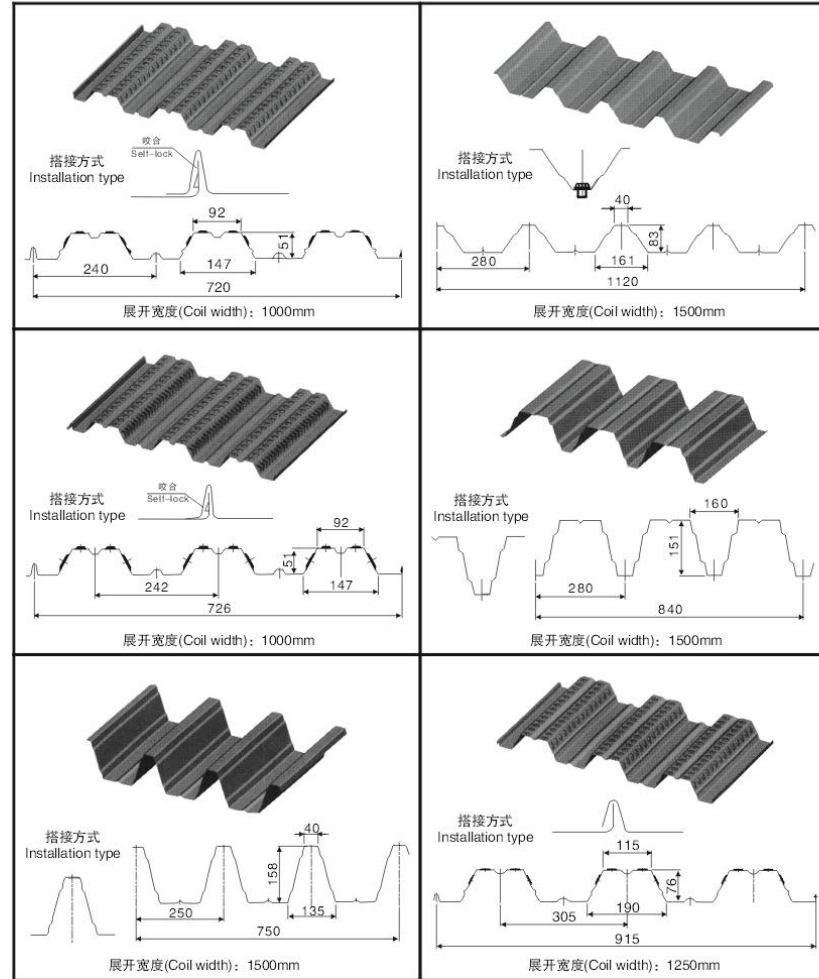
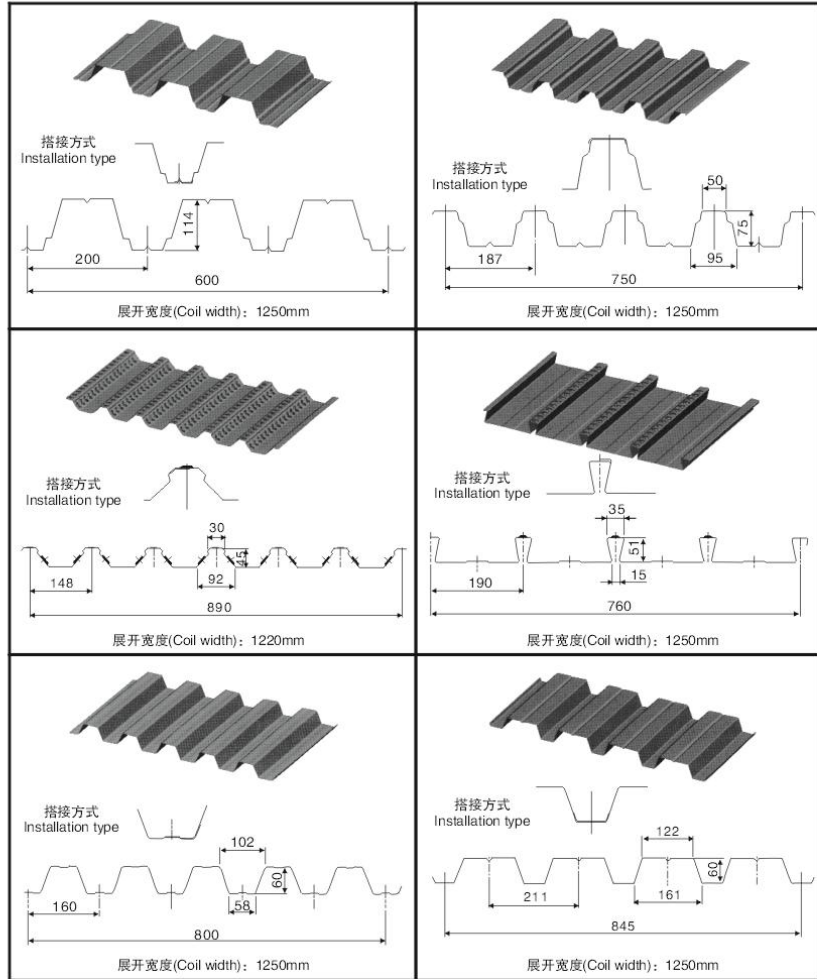

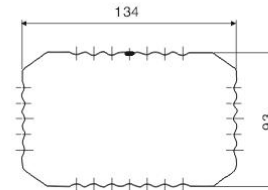
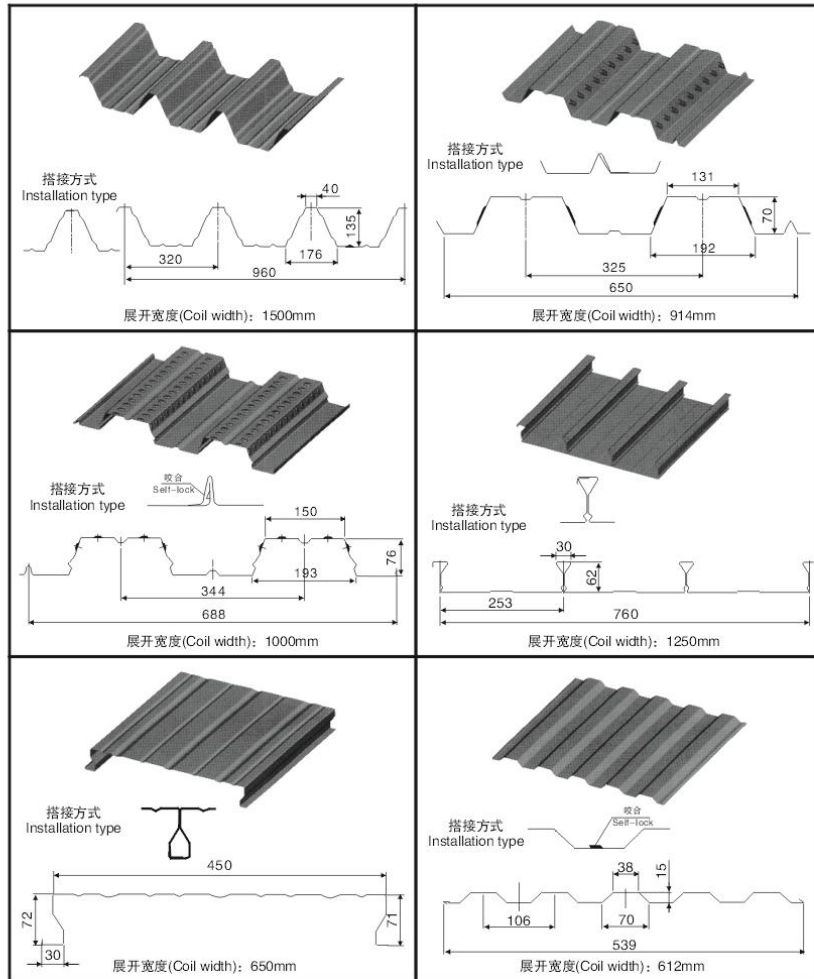

压型钢板机型号 Model	展开宽度(mm) Coil width	板厚 Thickness	用途 Usage
HS-134	437	0.5-0.6	落水管 Rainspout

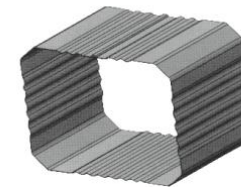
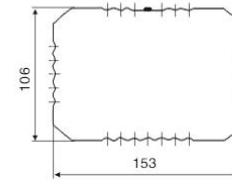

压型钢板机型号 Model	展开宽度(mm) Coil width	板厚 Thickness	用途 Usage
HS-153	500	0.5-0.6	落水管 Rainspout

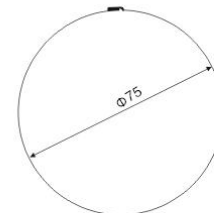

压型钢板机型号 Model	展开宽度(mm) Coil width	板厚 Thickness	用途 Usage
HS-75	260	0.5-0.6	落水管 Rainspout

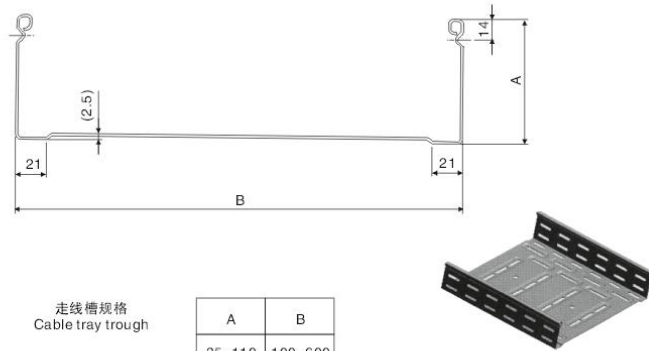

走线槽规格  
Cable tray trough

A	B
35-110	100-600

压型钢板机型号 Model	展开宽度(mm) Coil width	板厚 Thickness
HC-600	2A+B+36	0.8 1.5

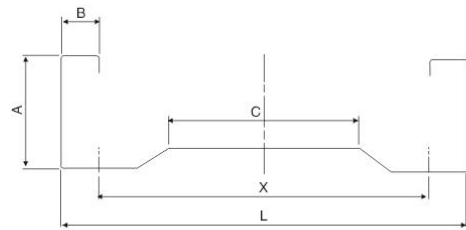

M型檩条规格  
Size of-shape purline

HV-220	70	15	98	180	220	1.5	395
HM-320	90	30	150	260	320	2.0	580
檩条机编号	A	B	C	X	L	板厚	展开宽度

压型钢板机型号 Model	展开宽度(mm) Coil width	板厚 Thickness
HM-320/220	580/395	2.0 1.5



M型檩条机规格  
Size-shape

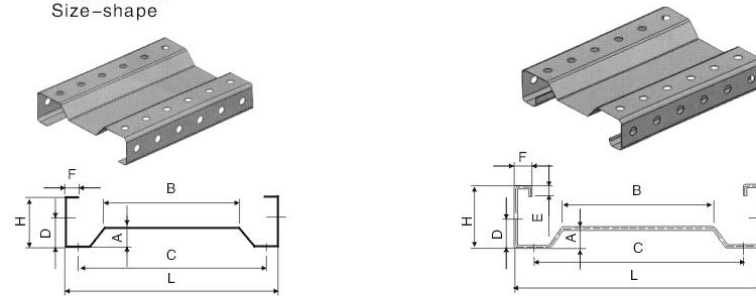

型号 Model	A	B	C	D	E	F	H	L	展开宽度(mm) Coil width	板厚(mm) Thickness
HCM-300	25	190	260	40		20	70	300	490	2.5-4
HCM-350	25	212	292	50	15	25	88	350	600	

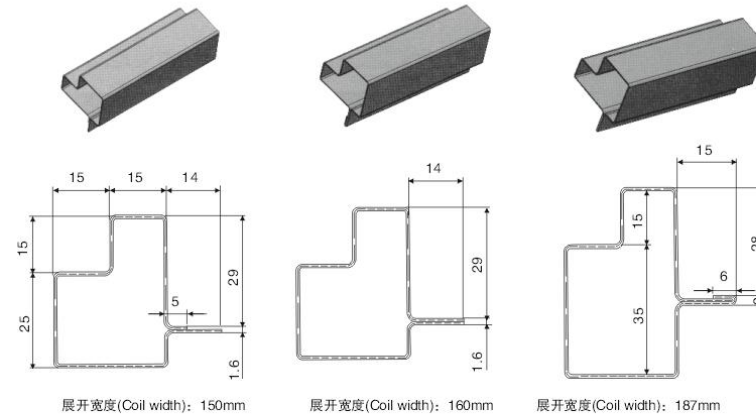

压型钢板机型号 Model	展开宽度(mm) Coil width	板厚 Thickness	用途 Usage
HQM-40	按照要求 According to the requirementd	0.3	创门框 Window doorcase

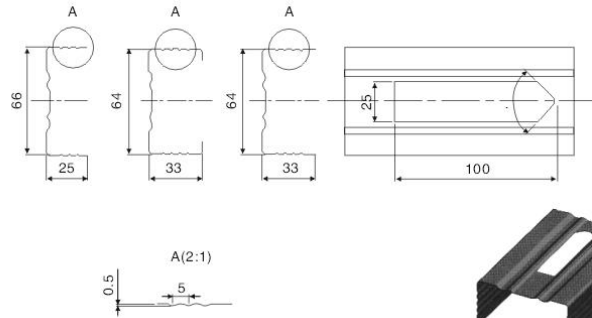

压型钢板机型号 Model	展开宽度(mm) Coil width	板厚 Thickness
HV-66A	115	0.38 0.63

L1 Width of L1	L2 Width of L2	展开宽度(mm) Coil width	备注 Remark
96.4	137	229	
86.4	127	212	
76.4	117	202	
66.4	107	192	
56.4	97	182	
46.4	87	172	
36.4	77	162	
26.4	67	152	
16.4	57	142	

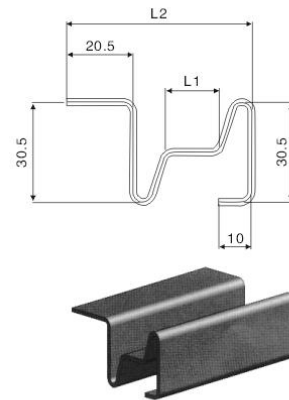

压型钢板机型号 Model	有效覆盖宽度(mm) Cover width	展开宽度(mm) Coil width	板厚 Thickness
HV-60B	见表	见表	1.43 2.50

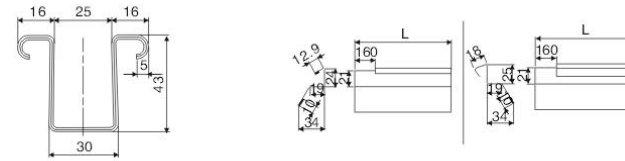

压型钢板机型号 Model	有效覆盖宽度(mm) Cover width	展开宽度(mm) Coil width	用途 Usage
HQ-30	30	150	导槽板 Guiding groove

压型钢板机型号 Model	展开宽度(mm) Coil width		用途 Usage
HQ-34	102	112	屋面扣板 Roof groove

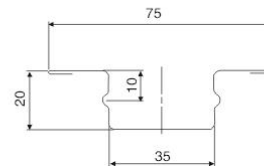

压型钢板机型号 Model	有效覆盖宽度(mm) Cover width	展开宽度(mm) Coil width	用途 Usage
Q-75A	35	130	导槽板 Guiding groove

压型钢板机型号 Model	展开宽度(mm) Coil width	用途 Usage
HQ-34	500	屋面扣板 Roof groove

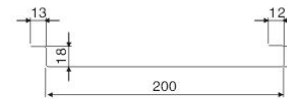
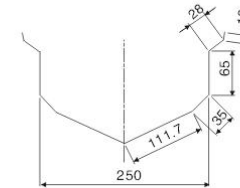

压型钢板机型号 Model	有效覆盖宽度(mm) Cover width	展开宽度(mm) Coil width	用途 Usage
HQ-200A	200	261	屋顶吊板 Hanging steel roof

压型钢板机型号 Model	展开宽度(mm) Coil width	用途 Usage
HQ-100	330	屋面扣板 Roof groove

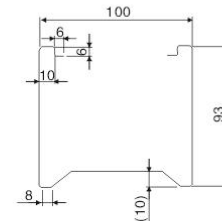

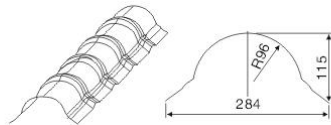

压型钢板机型号 Model	展开宽度(mm) Coil width	用途 Usage
HQ-300	385	弧形屋脊板 Curve ridge-cap

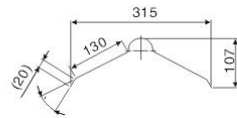

压型钢板机型号 Model	展开宽度(mm) Coil width	用途 Usage
HQ-130	396	弧形屋脊板 Curve ridge-cap

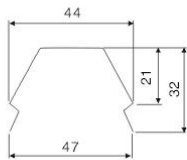

压型钢板机型号 Model	展开宽度(mm) Coil width	用途 Usage
HQ-24	95	屋面防水扣板 Leakage-resistance groove

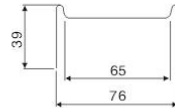

压型钢板机型号 Model	展开宽度(mm) Coil width	用途 Usage
HQ-III	162	屋面扣板 Roof groove

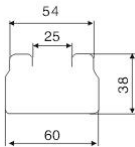

压型钢板机型号 Model	有效遮盖宽度(mm) Cover width	展开宽度(mm) Coil width	用途 Usage
HC-60	60	167	导槽板 Guiding groove

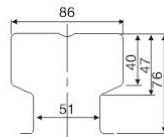

压型钢板机型号 Model	展开宽度(mm) Coil width	用途 Usage
HC-86	277	C型檩条 C-shape purlines



# 品质

## QUALITY

工艺 创新 服务 合作 发展 共赢

TECHNOLOGY INNOVATION SERVICE  
COOPERATION DEVELOPMENT WIN-WIN